

## Resilient Seated Gate Valve—PN25

### RSV—PN16 SANS 665

- Non Rising Spindle
- Fusion Bonded Epoxy Powder coated / Epoxy Coated
- Gate SG Iron EPDM Encapsulated
- NBR Encapsulated Gate on Request
- Drilled to BS4504; SANS1123 or blank as required
- Right hand or Left hand closing
- Cap top, hand wheel or gearbox operated

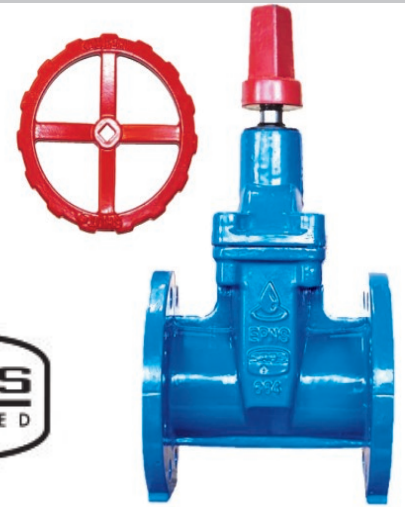

Material List		
Item	Part Name	Material
1	Cap Top	SG Iron - Grd 420/12
2	Bonnet	SG Iron - Grd 420/12
3	Cap Screws	HT Steel Grd 8.8 / SS - Grd 304
4	Bonnet Gasket	O Ring Type - Protects bolts against corrosion
5	Spindle	Stainless Steel - Grd 410 / 304
6	Gate Nut	Brass – DZR
7	Gate	SG Iron EPDM / NBR Totally Encapsulated
8	Body	SG Iron - Grd 420/12
9	Circlip	Stainless Steel - Grd 410
10	O-Ring	Nitrile Rubber - NBR
11	Seal	Polyurethane / Nylon
12	Bolt	SS - Grd 304 / 316 / HT Steel Grd 8.8
13	Dust Wiper Seal	Nitrile Rubber - NBR
14	Gland Housing	Brass – DZR
15	Washer	Brass – DZR
16	Coating	FBE 250 Micron Min. (Signal Blue)

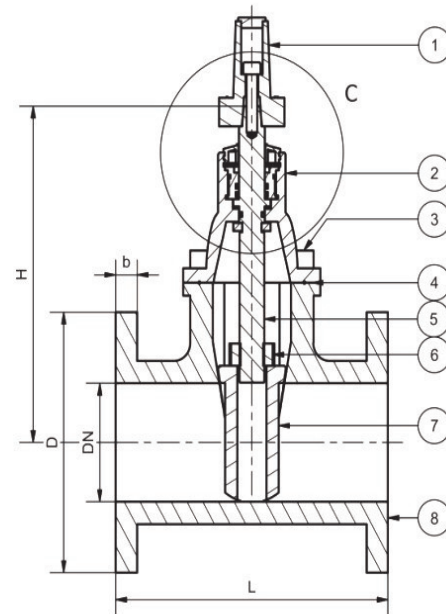

Dimensions					
DN	PN25 - L	D	H	Min - b	Mass (kg)
50	216	165	265	19	13
80	229	200	290	19	17
100	254	235	320	19	25
150	280	300	390	20	43
200	317	360	470	22	66
250	356	425	590	25	120
300	380	485	670	28	200
350	470	555	835	30	220
400	470	620	953	32	286
450	485	670	1080	35	380

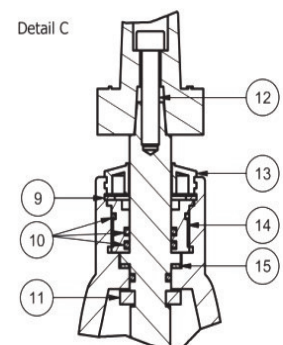

17 Resnick Street,  
Factoria,  
Krugersdorp,  
Gauteng.

Phone: +27 11 955 4690  
sales@spirotech.co.za

www.spirotech.co.za  
GPS: S26° 06,859'  
E027° 48,680'

Technical Queries:  
Martin Van Meygaarden  
+27 82 903 2917  
martin@spirotech.co.za